

NOTE 1: STRINGERS ARE EPOXIED OR SOLDERED IN PLACE.

NOTE 2: THIS IS THE FRAME, TO PROVIDE GOOD CONTACT ON THE RECEIVER AN EPOXY WEDGE IS MADE TO FILL THE GAP

<small>ALL ATTEMPTS HAVE BEEN MADE TO PRESENT AN ACCURATE DRAWING BASED ON THE SOURCE MATERIAL. USE SOURCE MATERIAL TO PROOF THIS DRAWING PRIOR TO USE. READ THE TECHNICAL NOTES ON THIS DRAWING PRIOR TO USE.</small> <small>IF ERRORS IN THIS DRAWING ARE DISCOVERED EMAIL JAYANDREW338@GMAIL.COM.</small>	TITLE:		
	<h2>Press Jig Assembly</h2>		
<small>MATERIAL</small> Alumnimum Flat Stock	<small>SIZE</small> B	<small>FIREARM MODEL</small> VZ-58	<small>REV</small> N/A
<small>DO NOT SCALE DRAWING</small>	<small>SCALE: 1:1</small>	<small>WEIGHT:</small>	<small>SHEET 1 OF 3</small>
<small>IF YOU LIKE WHAT YOU SEE HELP SUPPORT US DONATE VIA PAYPAL</small>			

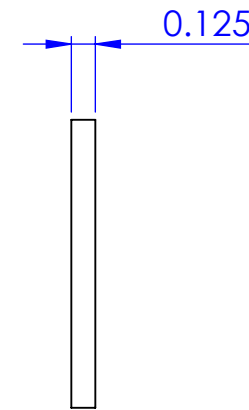
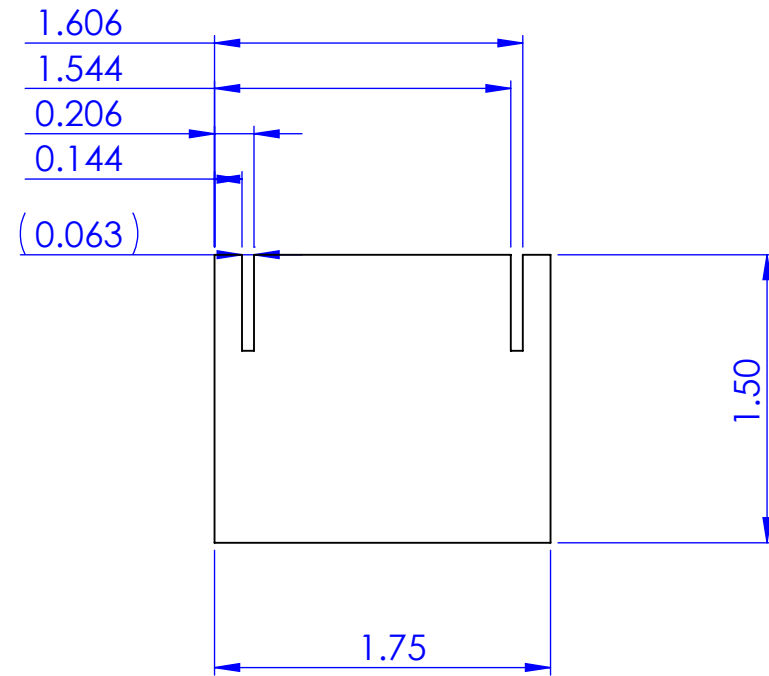
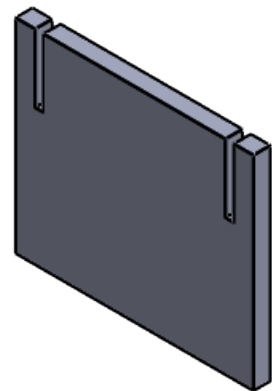

<small>ALL ATTEMPTS HAVE BEEN MADE TO PRESENT AN ACCURATE DRAWING BASED ON THE SOURCE MATERIAL. USE SOURCE MATERIAL TO PROOF THIS DRAWING PRIOR TO USE. READ THE TECHNICAL NOTES ON THIS DRAWING PRIOR TO USE.</small> <small>IF ERRORS IN THIS DRAWING ARE DISCOVERED EMAIL JAYANDREW338@GMAIL.COM.</small> <small>MATERIAL</small>		<small>TITLE:</small> Press Jig Plate	
<small>Aluminum Flat Stock</small>	<small>SIZE</small> B	<small>FIREARM MODEL</small> VZ-58	<small>REV</small> N/A
<small>DO NOT SCALE DRAWING</small>	<small>SCALE: 1:1</small>	<small>WEIGHT:</small>	<small>SHEET 2 OF 3</small>
<small>IF YOU LIKE WHAT YOU SEE HELP SUPPORT US DONATE VIA PAYPAL</small>			

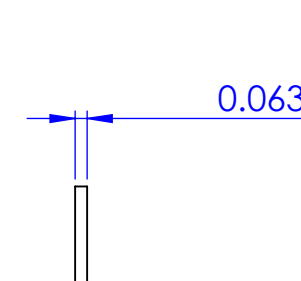
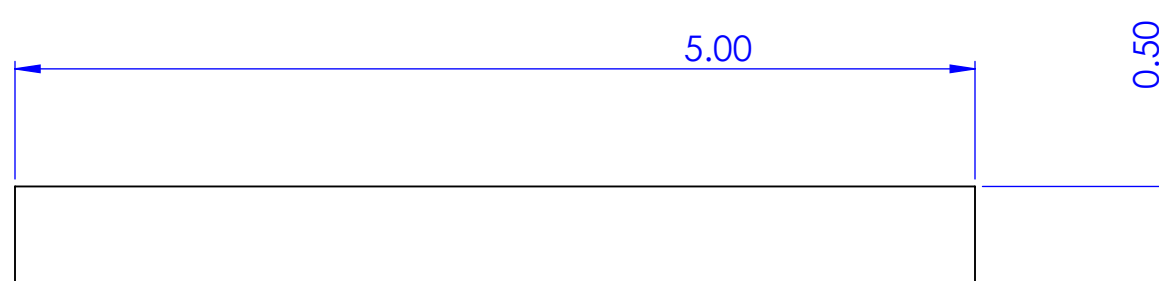

<small>ALL ATTEMPTS HAVE BEEN MADE TO PRESENT AN ACCURATE DRAWING BASED ON THE SOURCE MATERIAL. USE SOURCE MATERIAL TO PROOF THIS DRAWING PRIOR TO USE. READ THE TECHNICAL NOTES ON THIS DRAWING PRIOR TO USE.</small> <small>IF ERRORS IN THIS DRAWING ARE DISCOVERED EMAIL JAYANDREW338@GMAIL.COM.</small>		TITLE:	
<small>MATERIAL</small> Alumnimum Flat Stock		Press Jig Stringer	
<small>SIZE</small> B	<small>FIREARM MODEL</small> VZ-58	<small>REV</small> N/A	
<small>DO NOT SCALE DRAWING</small>	<small>SCALE: 1:1</small>	<small>WEIGHT:</small>	<small>SHEET 3 OF 3</small>
<small>IF YOU LIKE WHAT YOU SEE HELP SUPPORT US DONATE VIA PAYPAL</small>			