

NOTE 1: CONSTRUCTION IS ENTIRELY 3/8X1.5 MILD STEEL STOCK
 NOTE 2: FOUR 1/4-20X 2IN BOLTS ARE NOT SHOWN BUT ARE REQUIRED TO COMPLETE ASSEMBLY

<small>ALL ATTEMPTS HAVE BEEN MADE TO PRESENT AN ACCURATE DRAWING BASED ON THE SOURCE MATERIAL. USE SOURCE MATERIAL TO PROOF THIS DRAWING PRIOR TO USE. READ THE TECHNICAL NOTES ON THIS DRAWING PRIOR TO USE.</small> <small>IF ERRORS IN THIS DRAWING ARE DISCOVERED EMAIL JAYANDREW338@GMAIL.COM.</small>		TITLE: <h1>Barrel Blocks</h1>		
<small>MATERIAL</small> Mild Steel	SIZE B	FIREARM MODEL VZ-58	REV N/A	
<small>DO NOT SCALE DRAWING</small>	SCALE: 1:5	WEIGHT:	SHEET 1 OF 3	
<small>IF YOU LIKE WHAT YOU SEE HELP SUPPORT US DONATE VIA PAYPAL</small>				

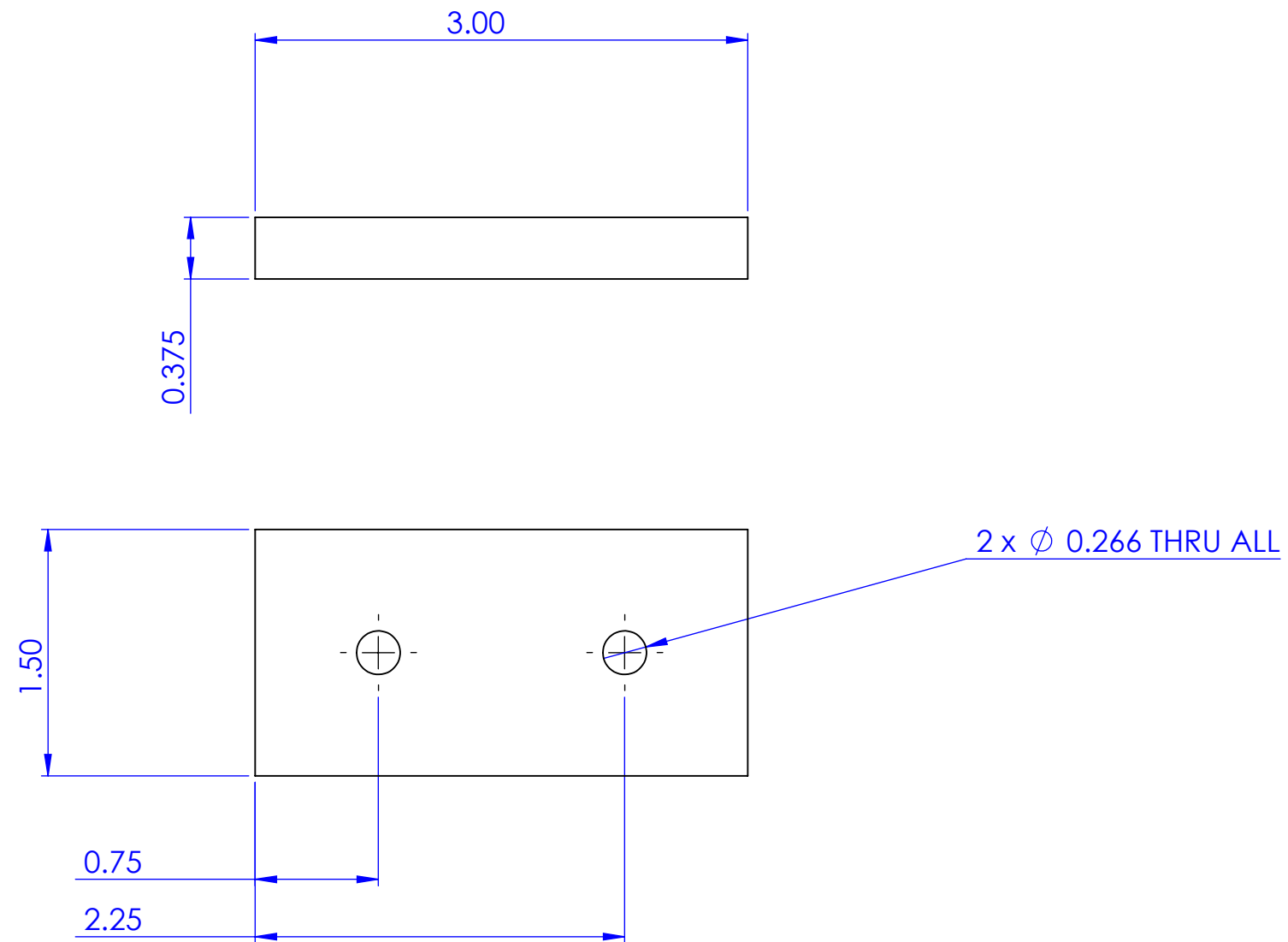

NOTE: HOLE SIZE SHOULD PROVIDE SUFFICIENT CLEARANCE FOR A 1/4X20 BOLT

<small>ALL ATTEMPTS HAVE BEEN MADE TO PRESENT AN ACCURATE DRAWING BASED ON THE SOURCE MATERIAL. USE SOURCE MATERIAL TO PROOF THIS DRAWING PRIOR TO USE. READ THE TECHNICAL NOTES ON THIS DRAWING PRIOR TO USE.</small> <small>IF ERRORS IN THIS DRAWING ARE DISCOVERED EMAIL JAYANDREW338@GMAIL.COM.</small>		TITLE: <h1>Cross Block</h1>	
MATERIAL Mild Steel	SIZE B	FIREARM MODEL VZ-58	REV N/A
<small>DO NOT SCALE DRAWING</small> <small>IF YOU LIKE WHAT YOU SEE HELP SUPPORT US DONATE VIA PAYPAL</small>	SCALE: 1:1	WEIGHT:	SHEET 2 OF 3

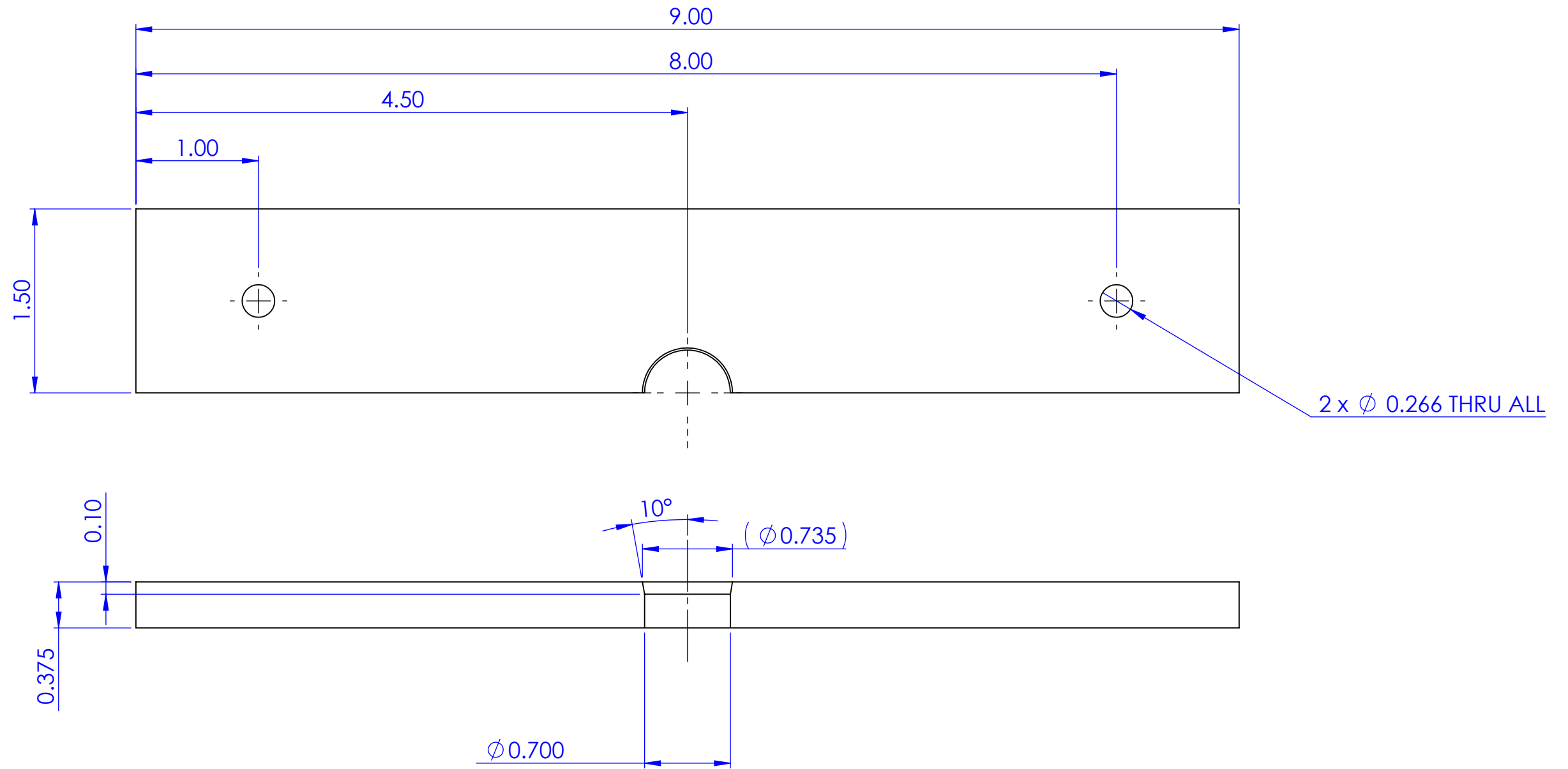

NOTE: HOLES FOR CROSS BLOCK SHOULD PROVIDE CLEARANCE FOR 1/4-20 BOLT

<small>ALL ATTEMPTS HAVE BEEN MADE TO PRESENT AN ACCURATE DRAWING BASED ON THE SOURCE MATERIAL. USE SOURCE MATERIAL TO PROOF THIS DRAWING PRIOR TO USE. READ THE TECHNICAL NOTES ON THIS DRAWING PRIOR TO USE.</small> <small>IF ERRORS IN THIS DRAWING ARE DISCOVERED EMAIL JAYANDREW338@GMAIL.COM.</small>		TITLE:	
MATERIAL Mild Steel		Barrel Block	
SIZE B	FIREARM MODEL VZ-58	REV N/A	
DO NOT SCALE DRAWING	SCALE: 1:1	WEIGHT:	SHEET 3 OF 3
<small>IF YOU LIKE WHAT YOU SEE HELP SUPPORT US DONATE VIA PAYPAL</small>			